

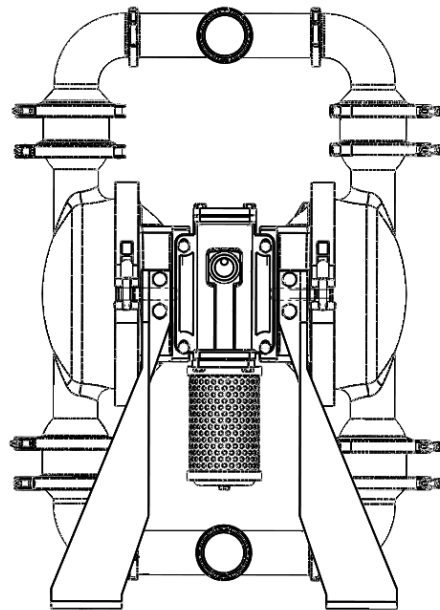

Specialist in Fluid Transfer

SKY-F-SE-03-2018



This manual contains warnings and caution.
READ AND RETAIN FOR REFERENCE

INSTRUCTIONS

SF40

FDA

Operation and Maintenance Manual

Diaphragm Pump

⚠ IMPORTANT

- Read the safety warnings and instructions in this manual before pump installation and start-up. Failure to comply with the recommendations stated in this manual could damage the pump and void factory warranty.
- When the pump is used for materials that tend to settle out or solidify, the pump should be flushed after each use to prevent damage. In freezing temperatures the pump should be completely drained between uses.

⚠ CAUTION

- Before pump operation, inspect all fasteners for loosening caused by gasket creep. Retighten loose fasteners to prevent leakage. Follow recommended torques stated in this manual.
- Nonmetallic pumps and plastic components are not UV stabilized. Ultraviolet radiation can damage these parts and negatively affect material properties. Do not expose to UV light for extended periods of time.
- Pump not designed, tested or certified to be powered by compressed natural gas. Powering the pump with natural gas will void the warranty.

⚠ WARNING

- When used for toxic or aggressive fluids, the pump should always be flushed clean prior to disassembly.
- Before maintenance or repair, shut off the compressed air line, bleed the pressure, and disconnect the air line from the pump. Be certain that approved eye protection and protective clothing are worn at all times. Failure to follow these recommendations may result in serious injury or death.
- Airborne particles and loud noise hazards. Wear eye and ear protection.
- In the event of diaphragm rupture, pumped material may enter the air end of the pump, and be discharged into the atmosphere. If pumping a product that is hazardous or toxic, the air exhaust must be piped to an appropriate area for safe containment.
- Take action to prevent static sparking. Fire or explosion can result, especially when handling flammable liquids. The pump, piping, valves, containers and other miscellaneous equipment must be properly grounded.
- This pump is pressurized internally with air pressure during operation. Make certain that all fasteners are in good condition and are reinstalled properly during reassembly.

The Skylink diaphragm pump is an air-operated, positive displacement, self-priming pump. These drawings show the flow pattern through the pump upon its initial stroke. It is assumed that the pump has no fluid in it prior to its initial stroke.

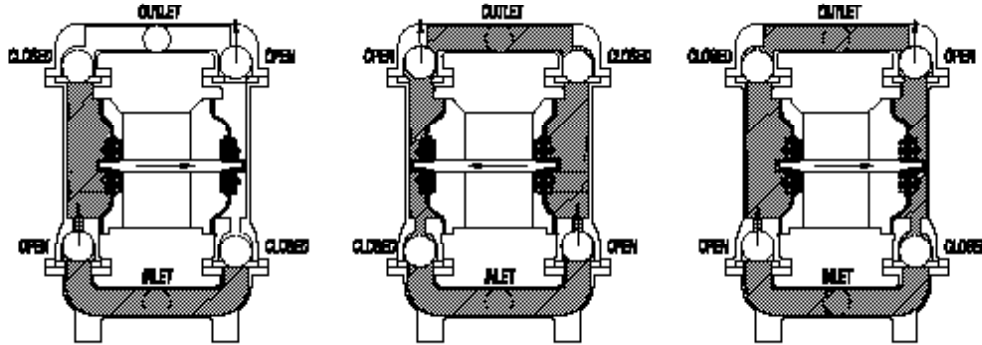

SKYLINK AODD pumps adopt compressed air for power source and depend on diaphragms which move left and right to reach the volume sealed working chamber to achieve loading and discharging.

AODD pump is structured by suction port, discharge port, medium chamber and air chamber, air chamber is structured by main air valve, pilot valve, thimble on left diaphragm chamber and right diaphragm chamber, medium chamber is structured by left medium, right medium and check valve. Check valve are set on the top or bottom, left and right medium chambers are connected by suction port and discharge port.

When AODD pump is working, left and right diaphragms are moving by compressed air, and the air valve has lubricating demand, so clear and dry air can improve the performance of AODD pump.

Compressed air comes into air chamber across air inlet port, after the regulation of pilot valve, compressed air come into left diaphragm chamber and drive diaphragm move on the left, the result is that the volume of left medium chamber decreases, the liquid is extruded.

Because the right diaphragm and the left diaphragm are connected by an axle, the right diaphragm moves to the left side, the right chamber volume increases, the liquid is inhaled. When the right diaphragm plate touches the right thimble, the right thimble can change the direction of compressed air by pilot valve, air come into the right chamber, the left and right diaphragm move to the right side, the left medium chamber volume increases, liquid is inhaled, the right chamber volume decreases, liquid is excluded. When the left diaphragm plate touches the left thimble, the air comes into left diaphragm chamber through pilot valve. The actions above are repeated complete the fluid continuous transporting on by AODD pump.

SKYLINK PUMP DESIGNATION SYSTEM

SF PUMP

文件编号: RD-TD-01-03

版本: 20180627Rev001

Model	Size	Wetted Parts	Non-Wetted Parts	Diaphragm	Valve Ball	MANIFOLD GASKET	Others
SF40/XAN/EEEEV/0K0	40	X	AN	EE	E	V	0K0

MODEL	SIZE	Wetted Parts	Non-Wetted Parts
SF=SKYLINK FDA	1"=25	X=316L STAINLESS STEEL	AN== NICKEL-PLATED ALUMINUM
	1.5"=40	S=304 STAINLESS STEEL	
	2"=50		
	3"=80		

DIAPHRAGM MATERIAL

MT= Teflon-EPDM BACKED

(PLATE INSIDE)

GE= Santoprene

(PLATE INSIDE)

MM= EPDM

(PLATE INSIDE)

VALVE BALL MATERIAL

E= Santoprene

M= EPDM

V=Viton

T= Teflon

X= Stainless Steel (316L)

S=304 STAINLESS STEEL

MANIFOLD GASKET

V= Viton

T= Teflon

M= EPDM

OTHERS

0K0= DIN Sanitary Connector

00C=Sensorstyle

Chemical Properties are as follows:

Materials	Chemical Properties
Virgin PTFE	injection molded thermoplastic elastomer with no fabric layer,Long mechanical flex life. Excellent abrasion resistance.
Santoprene	injection molded thermoplastic elastomer with no fabric layer,Long mechanical flex life. Excellent abrasion resistance.
Neoprene	All purpose, Resistant to vegetable oil. Generally not affected by moderate chemicals, fats, greases and many oils and solvents. Generally attacked by strong oxidizing acids, ketones, esters, nitro hydrocarbons and chlorinated aromatic hydrocarbons.
Buna	General purpose, oil-resistant. Shows good solvent, oil, water and hydraulic fluid resistance. Should not be used with highly polar solvents like acetone and MEK, ozone, chlorinated hydrocarbons and nitro hydrocarbons.
Viton:	Shows good resistance to a wide range of oils and solvents; especially all aliphatic, aromatic and halogenated hydrocarbons, acids, animal and vegetable oils. Hot water or hot aqueous solutions (over 70°F) will attack viton.
PVDF	Athermoplastic polymer.Moderate tensile and flex strength.Resists strong acids and alkalie.Attacked by chlorine,funming nitric acid and other strong oxidizing agents.
Polypropylene	Athermoplastic polymer.Moderate tensile and flex strength.Resists strong acids and alkalie.Attacked by chlorine,funming nitric acid and other strong oxidizing agents.
Alloy C	equal to ASTM494 CW-12M-1 specification for nickel and nickel allo .
EPDM	Shows very good water and chemical resistance. Has poor resistance to oil and solvents, but is fair in ketones and alcohols,
Stainless steel	equal to exceeding ASTM specification A743 CF-8M forcorrosion resistant iron chromium,iron chromium nickel,and nickel based alloy castings for general applications. Commonly referred to as 316 Stainless Steel in the pump industry.

For specific applications,you can contact u .

SECTION 3

3.4 Temperature limitations

Operating temperature limitations are as follows:

Materials	Maximum	Minimum
Virgin PTFE	212 °F 100°C	-35 °F -27°C
Santoprene	212 °F 100°C	-10 °F -23°C
Neoprene:	200 °F 93°C	-10 °F -23°C
Buna:	190 °F 88°C	-10 °F -23°C
Viton	350 °F 177°C	-40 °F -40°C
PVDF	250 °F 121°C	0 °F -18°C
Polypropylene	180 °F 82°C	32 °F 0°C
EPDM	280 °F 138°C	-40 °F -40°C
Alloy C	-	-
Stainless steel	-	-

For specific applications, you can contact us .

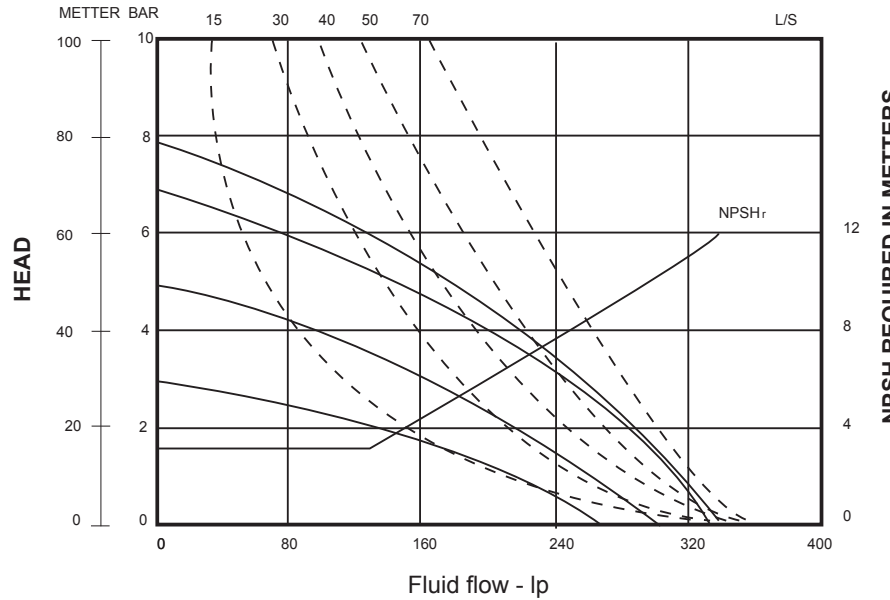
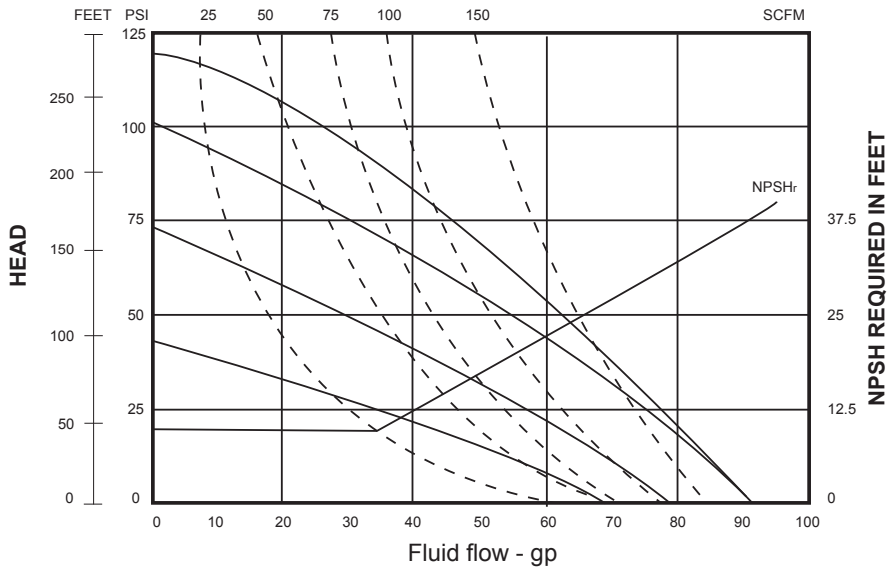

*Performance is based on the following: elastomer fitted pump, flooded suction, water at ambient conditions. The use of other materials and varying hydraulic conditions may result in deviations in excess of 5%.

SECTION 3

3.6 F40 Dimensional Drawing (Thread)

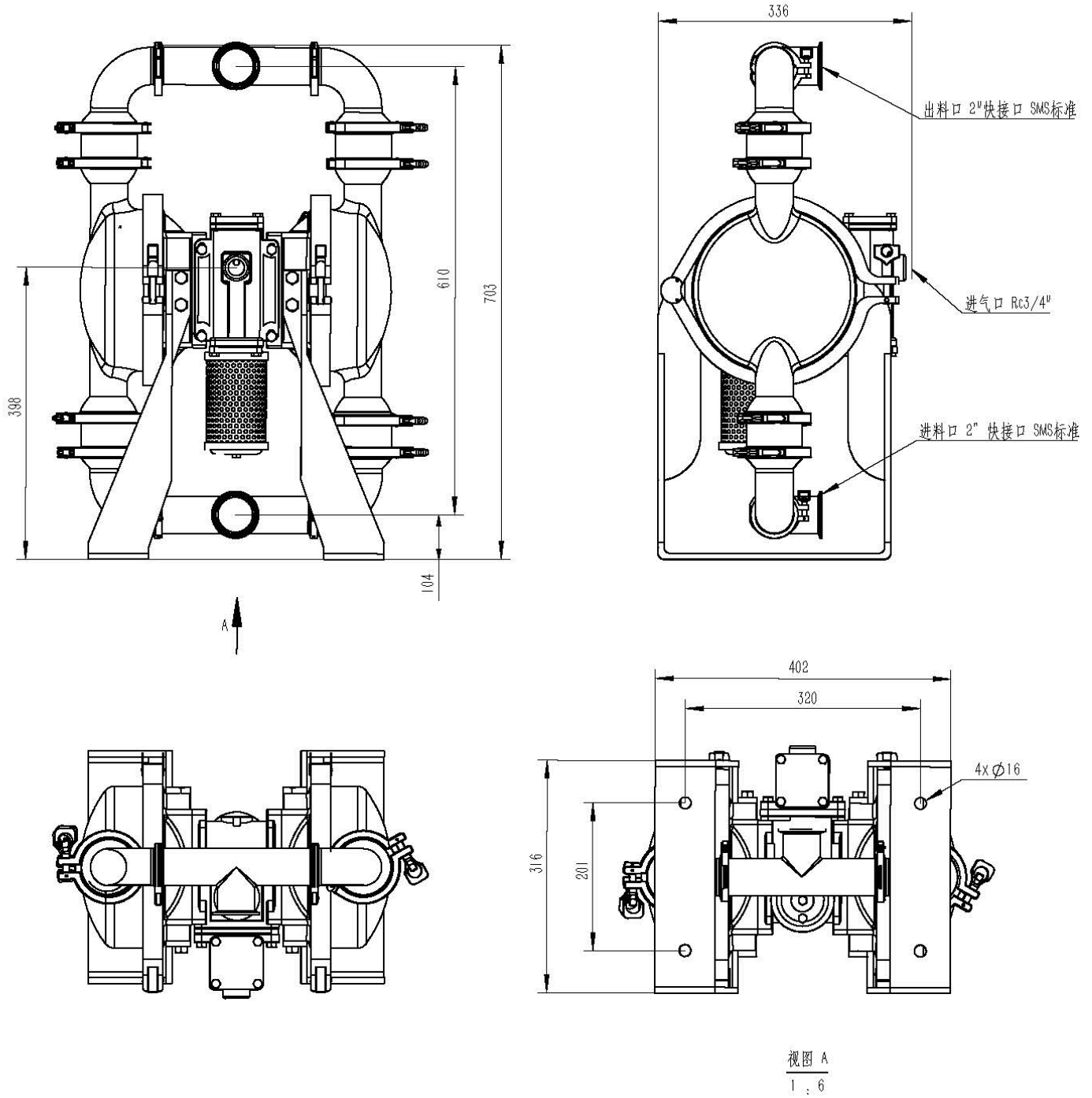

* The dimensions on this drawing are for reference only. A certified drawing can be requested if physical are needed.

SECTION 4

4.1 Exploded View & Parts Listing

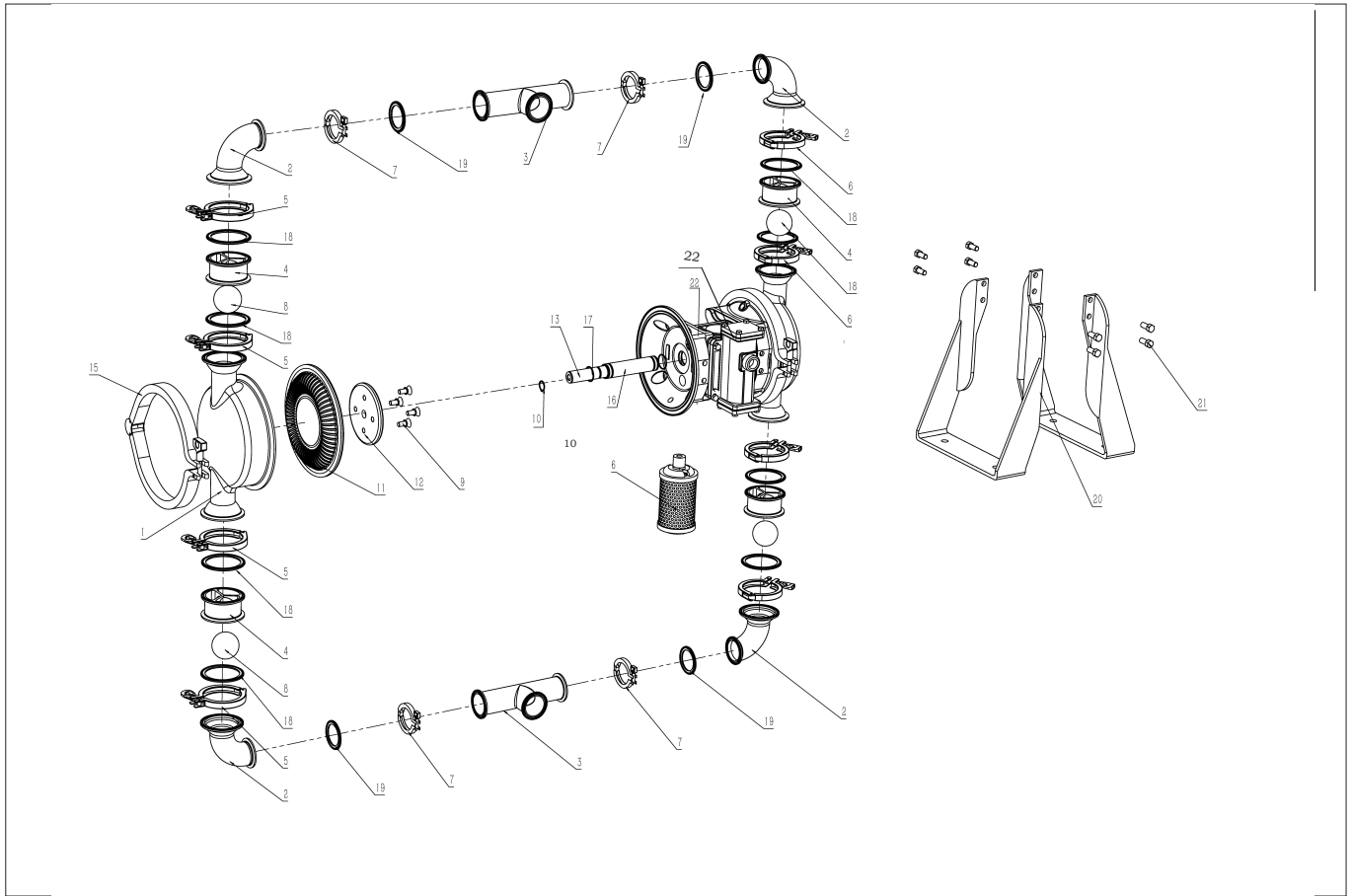

项目号	零件号	说明	数量
1	F40外腔体		2
2	F40料口弯头		4
3	F40三通		2
4	F40球桶		4
5	91卡箍		8
6	消音器		1
7	64卡		4
8	球		4
9	沉头内六角 M8*1.25-15		8
10	卡簧		2
11	F40复合膜片		2
12	F40内压板		2
13	中间轴		1
15	1513017-000240		2
16	SK50中间轴套筒		1
17	O-ring		2
18	卡91 卡盘垫片 teflon		8
19	卡64 卡盘垫片 teflon		4
20	支架		1
21	支架螺丝		8
22	中间体组件		1

SECTION 4

4.3 Center intermediate Drawing 中间体分解图

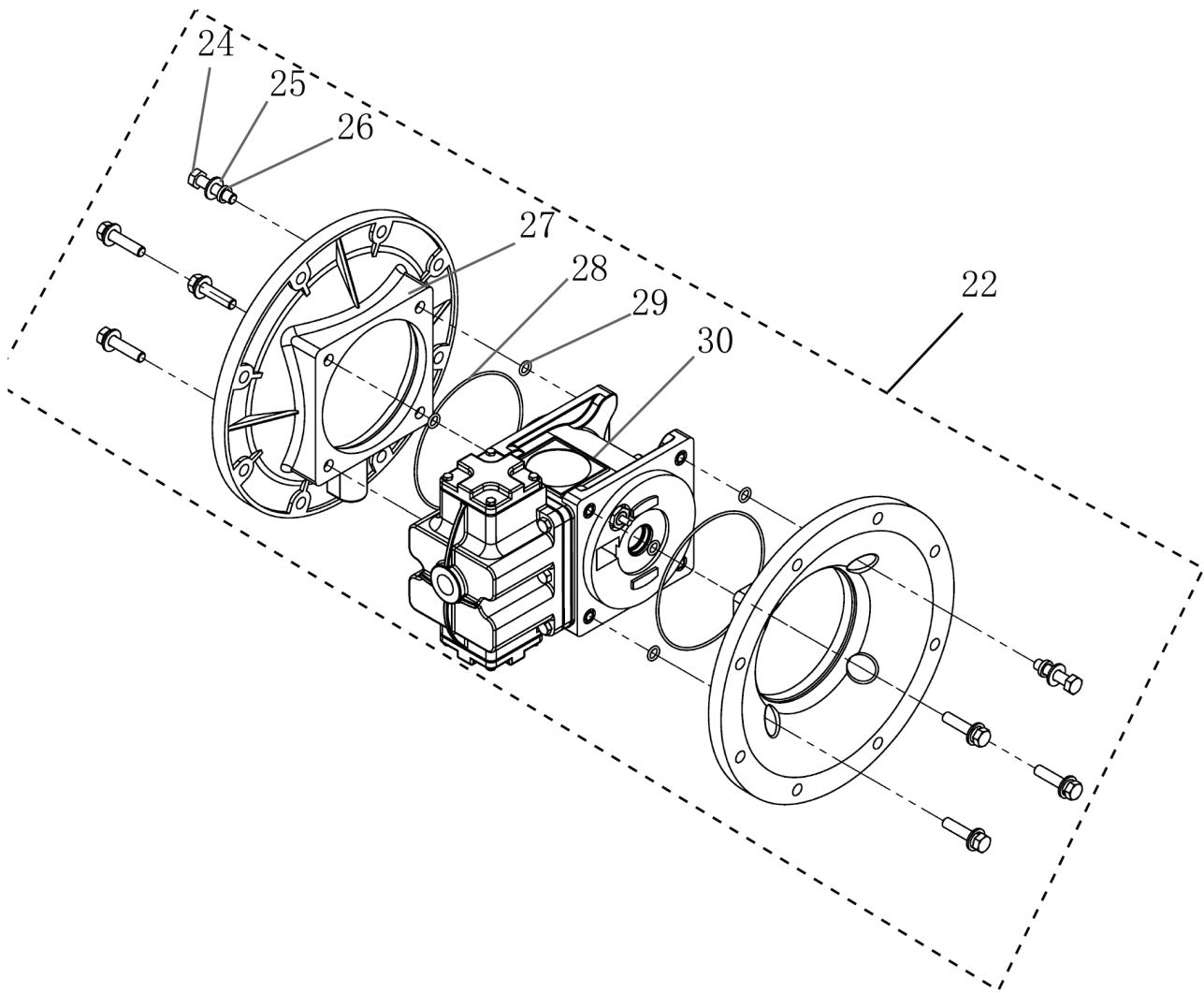

Center intermediate Parts List 中间体零件图

Number图号	Part Number零件编号	Description描述	Quantity数量
Center intermediate Assembly 中间体组件			
22	3040.3700	Bracket, Intermediate 1-2寸中间体	1
24	1458.1390	Screw 1.5-3寸中间体螺丝	8
25	4050.1490B	Flat Pad 平垫	8
26	4050.1490C	Spring Washer 弹垫	8
27	3040.2691	Chamber, Inner 2寸内腔体	2
28	1458.7251	"O"ring 1.5-3寸中间体O型圈	2
29	1458.7551	"O"ring 1.5-3寸中间体螺丝O型圈	8
30	3045.3700	Bracket, Intermediate Assembly 1-2寸中间体组件 (不含内腔体)	1

Center intermediate Parts List 中间体零件目录

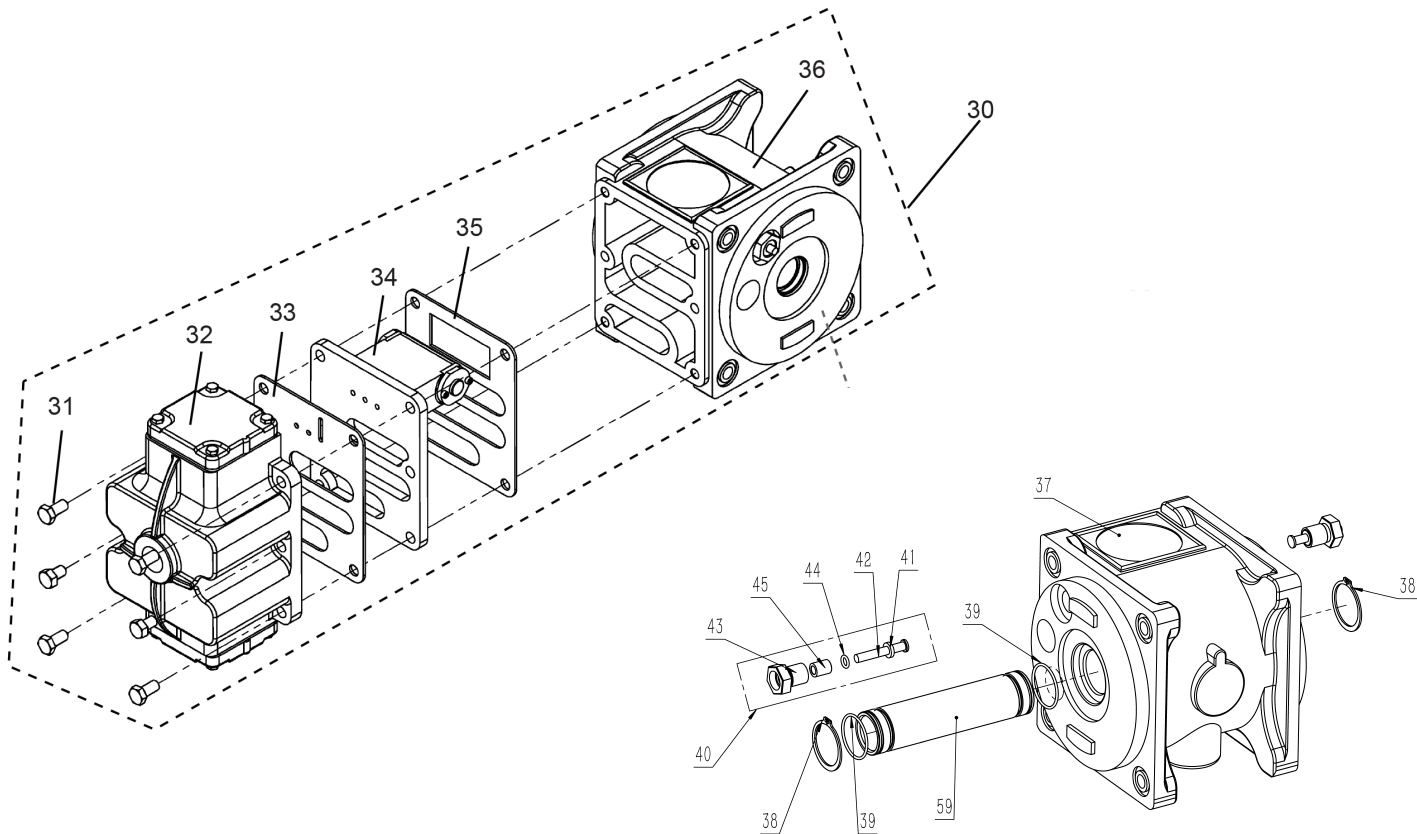

Number图号	Part Number零件编号	Description描述	Quantity数量
Center intermediate Assembly			
30	3045.3700	Bracket,Intermediate Assembly 1-2寸中间体组件 (不含内腔体)	1
31	0080.1199	Screw 主气阀螺丝	4
32	1458.4600N	Sliding Style Main Valve 1.5-3寸主气阀组件	1
33	1458.7039	Main Gasket.Cap 1.5-3寸主气阀密封垫片	1
34	1458.4100N	Pilot Valve 1.5-3寸导向阀组件	1
35	1458.6639	Gasket.Cap 1.5-3寸导向阀密封垫片	1
36	1045.3701N	Bracket,Intermediate 1.5-2寸中间体组件 (不含内腔体气阀导向阀)	1
37	1045.3791GN	Bracket,Intermediate 1.5-2寸中间体	1
38	1045.9789	Snap rings 1.5-2寸中间轴套筒卡簧	2
39	1045.9651	O-ring 1.5-2寸中间轴套筒O型圈	2
40	1458.8092	Bumper,plung 1.5-3寸顶针座	2
41	1458.5651	O-Ring 1.5-3寸顶针垫圈	2
42	1458.3593	Pin,Actuator 1.5-3寸阀套式顶针	2
43	1458.8000	Bumper,plung 1.5-3寸顶针组件	1
44	1458.7351	Oring 1.5-3寸顶针O型圈	2
45	1458.3642	Bush 1.5-3寸顶针袖套	2
59	1045.9540	Bush 1.5-2寸中间轴套筒	1

SECTION 4

4.5 Air Valve Drawing 气阀分解图

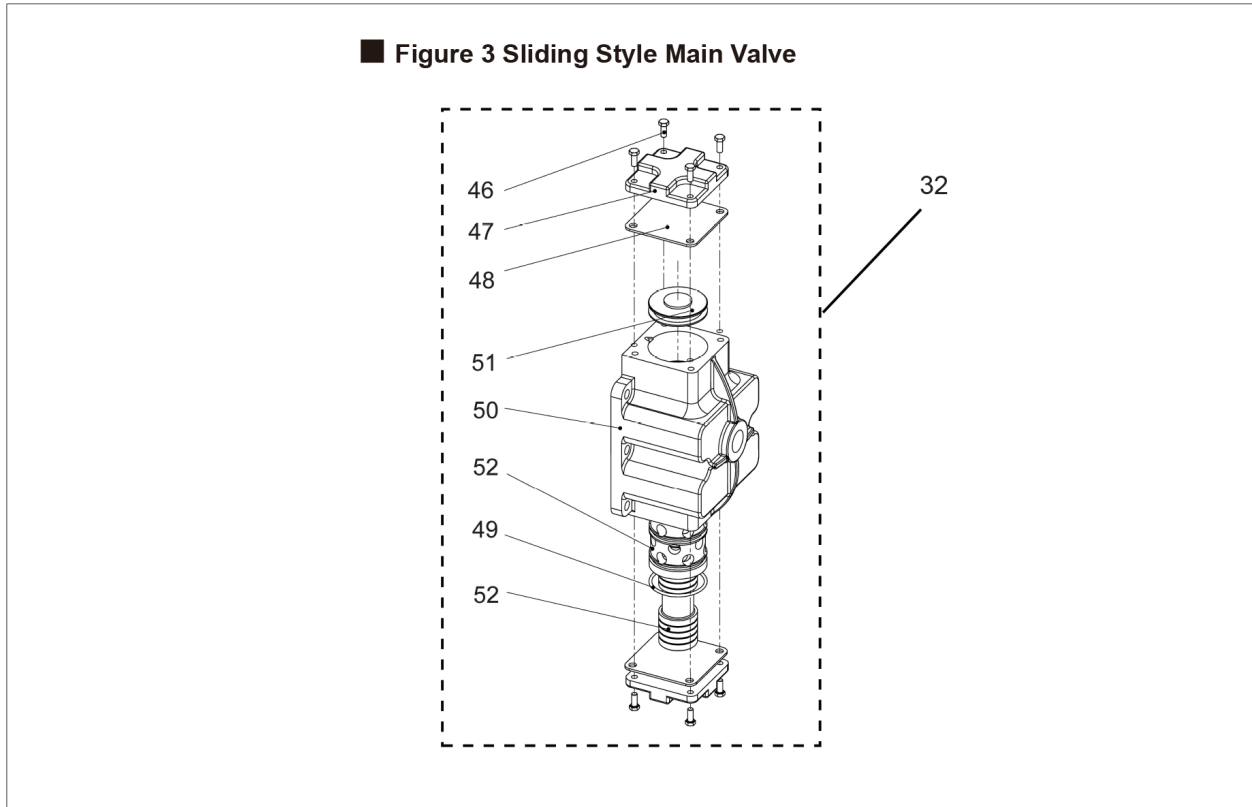

Air Valve List 气阀零件目录

Number 图号	Part Number 零件编号	Description 描述	Quantity 数量
Sliding Style Main Valve 滑阀式主气阀			
32	1458.4600N	Sliding Style Main Valve 1.5-3寸主气阀组件	1
46	1458.0891	Screw 1.5-3寸主气阀端部螺钉	8
47	1148.4899N	Cap,End 1.5-3寸主气阀端部挡板	2
48	1458.7151	Gasket,Cap 1.5-3寸主气阀端部垫片	2
49	1458.6751	O-Ring outside 1.5-3寸主气阀外层O型圈	6
50	1458.4791N	Air valve 1.5-3寸主气阀外壳	1
51	1458.9000	Piston 1.5-3寸活塞组件	1
52	1458.5291	Spool Assembly 1.5-3寸主气阀滑阀芯阀套	1

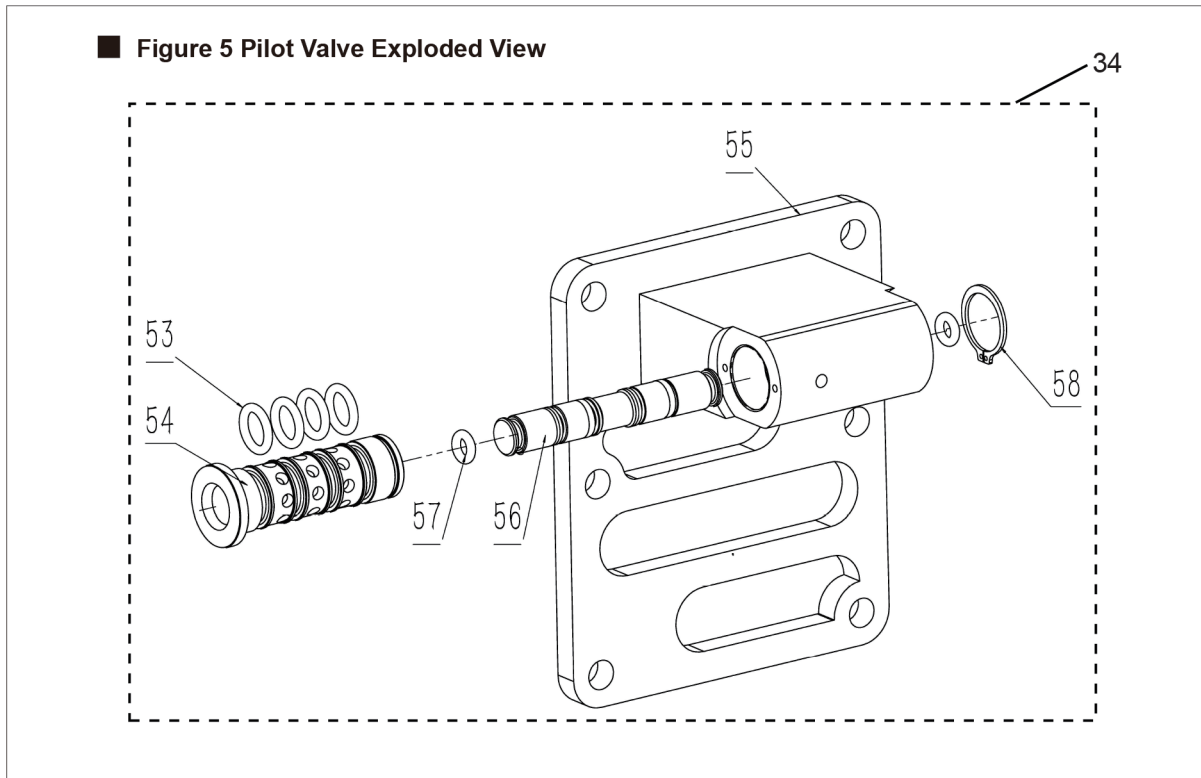

■ Pilot Valve List 导向阀零件目录

Number图号	Part Number零件编号	Description描述	Quantity数量
Pilot Valve导向阀			
34	1458.4100N	Pilot Valve 1.5-3寸导向阀组件	1
53	1258.6851	O-Ring 1-3寸阀套式导向阀阀套O型圈	4
54	1458.4291	Spool Bush 1.5-3寸阀套式导向阀阀套	1
55	1458.4391N	Pilot Valve 1.5-3寸导向阀阀壳	1
56	1458.4400	Spool 1.5-3寸阀套式导向阀阀芯组件	1
57	1258.8451	O-Ring 1-3寸阀套式导向阀阀芯减震圈	2
58	1258.4589	Snap rings 1-3寸阀套式导向阀卡簧	1

Recommended Installation

SKYLINK AODD pumps are able to fulfil different requirements of most demanding fluid transfer, they are designed as well as manufactured in such high quality, in order to satisfy our clients' various demands. SKYLINK provides diaphragms which are made of different elastomeric materials to be suitable for different environments according to clients' requirements.

Piping:

The pipes which are connected to the inlet and outlet must be incompressible material, so that those pipes are able to bear a high vacuum. All piping should be equivalent size or larger than the diameter of the inlet and outlet, which will improve pump's performance.

Installation:

Engineer and installation personnel shall propose an integrated installation plan, which will make pumps perform better, meet fluid transfer requirement and easier to maintain in the future.

Location:

When install pumps, enough space shall be left for maintenance personnel to do maintenance or even rebuild your system, such as add a pressure gauge or a valve on the pump in the future.

Air supply:

Each pump must have a sufficient air supply to meet the pump's air demand, if air supply is not powerful enough, the pump will not reach its best performance. Use air pressure up to 8.6 bar (125 Psig) according to different pumps.

In addition, proper air filter and regulator are also important for pump to its performance, so SKYLINK recommends that a 5 μ (micron) air filter shall be applied before pump's air inlet.

Solenoid control

If air supply of pump is controlled by solenoid valve, a three-way valve shall be applied in order to release the air which is stuck between the pump and valve.

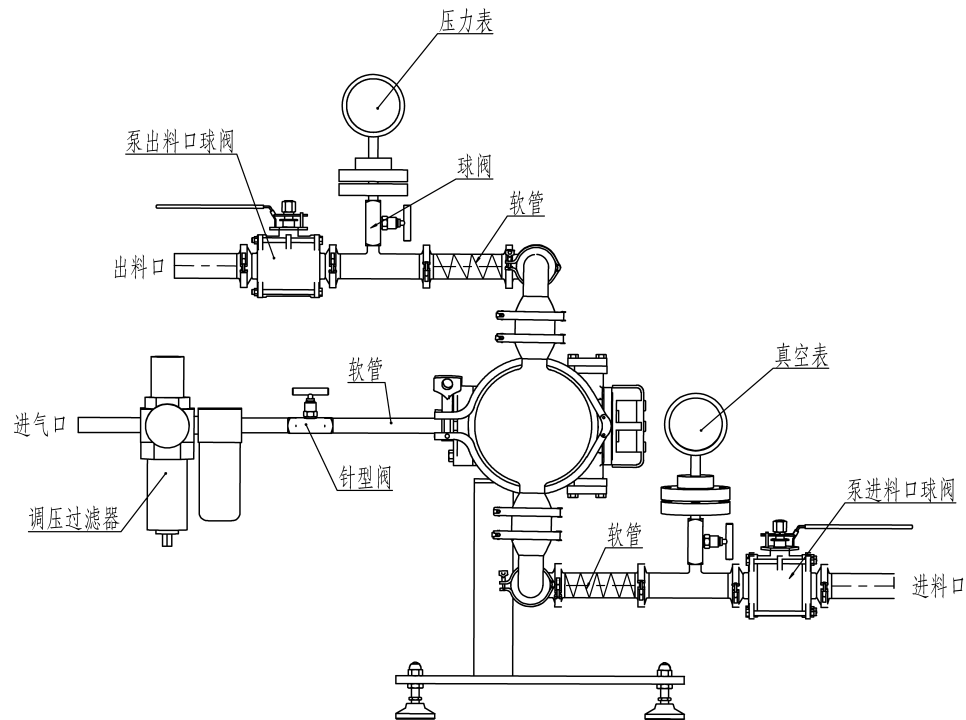
**Operation:**

Do not lubricate the pump before operate, because it is pre lubricated, additional lubrication will not damage the pump, however if the pump is heavily lubricated by an external source, the pump's internal lubrication may be washed away. If the pump is over-lubricated, when the pump is moved to a non-lubricated location, it shall be dismantled and re-lubricated as disassembly/reassembly section.

The flow rate of the pump can be adjusted according how powerful the air supply is, an air regulator is used to regulate air pressure, and the needle valve is to regulate volume.

Maintenance:

Different working condition (Frequency of use, air pressure, viscosity of fluid and abrasiveness of process fluid) affects parts life of pumps, so each pump must have its own maintenance schedule. Before operating the pump, a visual inspection shall be taken, check all fasteners, tighten if they are loose.

Records:

Each maintenance shall be recorded, those records will become a useful tool to predict and avoid some potential issues which would happen in the future. Furthermore, an elaborate record can identify if the pump is truly suitable for such application as well.

For best cleaning results, consider the following information prior to cleaning the pump. (For the Drawing ,please refer to page 9)

- COP cleaning

Cleaning parts: 1、 2、 3、 4、 9、 21、 49、 50

Cleaning standard:

1. Odor: Fresh and odorless, with a slight odor allowed for special treatment or special stage, but without affecting the safety and quality of the final product.

2. Vision: Clean the surface, bright, no water, no film, no dirt or other; Health indicators microbial indicators meet the relevant requirements; can not cause the improvement of other health indicators of products.

Dismantling and cleaning steps:

1. First, turn off the intake valve to ensure that there is no pressure at the outlet.
2. Remove the clamp No. 6 and place 4, 9 and 50 at the cleaning pool in order to wait for cleaning.
3. Remove the clamp number 8 and place 2, 49 and 3 next to the cleaning pool in order for cleaning.
4. Remove the clamp number 25 and place 1, 21 next to the cleaning pool in order to wait for cleaning.
5. Use brush to dip in the cleaning solution and clean the inner and outer surfaces of each dismantled and decomposed part. If necessary, soak in alkaline or acidic detergent to reach the cleaning standard.
6. The parts after immersion and sterilization are assembled in the order of steps 5-4-3. After all the parts are loaded, they are connected with the inlet and outlet pipes, the compressed gas is connected, and the sealing performance of the pump is tested.

NOTE: A typical the cleaning temperature limit is 90° C (195° F). If the temperature is greater than 90° C (195° F), damage to the pump may occur.

- For best Clean results, the pump should be configured to 3-A configurations
- Actual effectiveness with pump user' s product(s) and processes should be validated on location by the end user' s quality assurance personnel to meet internal guidelines.
- The pump user should establish periodic inspections with full tear down to verify that processes continue to be effective as first validated.
- Inlet pressure to the pump should not be greater than 0.7 bar (10 psig). Premature diaphragm failure will occur if greater than 0.7 bar (10 psig) is applied. If the pump is to be subjected to greater than 0.7 bar (10 psig), an optional diaphragm balancing device is suggested to eliminate the possibility of the diaphragms being forced against the air chamber and subsequently causing premature diaphragm failure.

SECTION 7

Troubleshooting Guide

Malfunction description	Reason	Solution
pump is working, but no fluid is discharged or low outlet pressure, few fluid is discharged.	due to serious damage of check valve(ball & seat), so that it is not able to seal properly	dismantle both upper and bottom seat, if a huge gap between ball and seat, ball can be changed, seat can be continue using if filp
	main valve serious damage, air leakage	change spool valve & valve bush of main valve
	fluid inlet or pipe are unseale	check if fluid inlet and pipe are sealed properl
	exceed pump's performance	ajust installation position of pump, as closer to flu d as possible
	"O" ring of pilot valve damages	check pilot valve
	damage of internal spring or ""O"" ring of quick adapter which is connected to the pump	dismantle quick adapter, check if it works after connect to the air source
	unsealing due to loosen bolts	tightening all bolts
	outlet is blocked	check outlet and valve opening
	ball is not able to fully return by its own weight and seal due to high viscocity of flui	change a heavier ball or stainless steel ball
	Unsealing due to damage of "U" ring of shaft, "O" ring of thimble or gasket of pilot valve.	check all rings, gaskets, change if damaged
	"fluid leaks out form muffler due to damage o diaphragm or washer."	change diaphragm, tightening washer
	insufficient air pressure or air fl	increase air pressure or air flo
	flow limit due to inflation of ba	check chemical compatibility of ball material and flui
pump is not working	main valve is stuck, unmovable by hand serious damage of spool valve of main valve, huge gap causes air leakage	change spool valve & valve bush
	pores of pilot valve are blocked, "O" ring of valve bush damages seriously, air leakage	clean up valve casing,change "O" rings
	valves of inlet and outlet stay shut	release valves
	muffler is blocked, air su focate	change muffle
	damage of thimble sealing, thimble socket; bend of thimble and other issue	change thimble and socket
	thimble falls into mid chamber	change mid chamber
	excessive lubrication	decrease lubricating oil volume in oil-water separator
	air leakage due to "U" ring of shaft damages seriously	change "U" ring
	air valve stays shut	solenoid valve fails or air source is shut
	mid chamber occurs pores due to corrosion	change mid chamber
	air valve, pilot valve, air inlet gasket damage	change damaged parts
	material solidified in chambe	dismantle chamber and clean up

Malfunction description	Reason	Solution
pump is working after outlet valve is shut	outlet valve is not totally sealed	shut outlet valve totally or change it
	check valve(ball & seat) is not totally sealed, sundries might be stuck between	change check valve(ball & seat) of clean sundries
after a period of time works normally, the pump fails to work, then it back to normal again after a few hours in winter time	pump is frozen	keep air source dry and moisture percentage of air source as less as possible. release water in air compressor, air container air pipes on time
		change surrounding environment, keep warm in order to avoid freezing
		slow down working frequency, so that avoid freezing
		add a few lubricating oil, lower the freezing point
noise or abnormal sound	sound due to ball in the pump shell	
	mid chamber occurs a loud noise when release air	change muffle
outlet occurs bubble	inlet or inlet pipes are not sealed properly	check if fluid inlet and pipe are sealed properl
	air leakage due to damage of diaphragm or looseness of washer	change diaphragm, tightening washer
fluid leaks from chambe	leakage occurs around bolt	retightening bolt
	leakage occurs around muffle	check diaphragm and washer